



HARMONIC FILTERING

AFQs

Active multifunction filter with
silicon carbide (SiC) technology

Innovation in filtering: Greater efficiency, less space



The use of devices that convert current from AC to DC, known as non-linear loads, has spread to industrial applications and services. Industry routinely uses solutions such as variable speed and frequency drives, automation and control systems, HVAC machinery, cold storage rooms, forklifts, pumping systems, LED lighting and electric vehicle charging systems. Although these technologies improve equipment performance, they generate harmonics that distort the current and voltage waveform, causing problems such as energy losses, overheating and production system failures.

With the **AFQs** range, we are enhancing the market of filtering solutions thanks to the implementation of cutting-edge technology based on SiC power electronics. This new solution is currently the most reliable on the market, used to generate currents that cancel the harmonics generated in the installation, to compensate for reactive power, whether inductive or capacitive, and to balance the phase currents. One indirect benefit is the mitigation of flicker.

The unique ability of SiC to handle high frequencies and voltages makes it an ideal material for active harmonic filtering applications.

AFQs

Active multifunction filter with Silicon Carbide (SiC) technology

The **AFQs** active filter, with Silicon Carbide technology, uses the most advanced power electronics and the most innovative control systems to cancel the harmonics generated by non-linear loads. It also compensates reactive energy, both inductive and capacitive, and it balances the phase current.

The device allows the filter power to be modified to protect against resonances or high temperatures, and it has an alarm system that reports incidents in real time.



More efficient
> 98%



Lighter
only 13 kg











Smaller
70% reduced



More filtering power

Main characteristics of the AFQs filter

-  Rated filtering capacity for currents of 30 A
-  Small cabinet with easy installation on walls, in motor panels or with variable speed drives
-  Range for 3-wire installations
-  Multi-range voltage and frequency (50/60 Hz)
-  Reduces up to 50th order harmonics
-  Selectable harmonic frequencies to filter to maximize the filtering efficiency
-  Reactive power compensation (inductive/capacitive)
-  Balanced phase currents in unbalanced networks.

AFQs: It avoids problems caused by harmonics

The presence of harmonics in electrical installations creates a series of problems that directly affect the performance of the installation, such as:

- › Premature deterioration of capacitors (capacitor banks)
- › Deterioration of power supplies of electronic equipment
- › Malfunction or resets in production/IT systems
- › Loss of performance in motors and pumps
- › Increase in current and loss of insulation in conductors Shorter useful life in LED lights
- › Electrical protection trips.

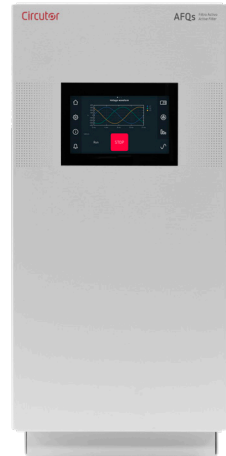

What does the new SiC technology offer?

The implementation of SiC technology improves the performance of this solution compared to other devices. This feature makes the device much more compact than its predecessor, the AFQm-30, reducing its volume by 70% and its weight by up to 40%.

This reduction in size and weight makes it easy to install, whether in panels with variable-speed drives right at the point where the harmonics that can damage the rest of the electrical installation are generated, or in any electrical room. In short, this new technology increases the filtering efficiency and reduces losses, in a compact, robust and reliable device.

Improve your facility's efficiency



Harmonic filter

It eliminates harmonics to clean the installation's waveform.

Reduction of harmonic currents up to the 50th harmonic (2500 Hz).
Option to select the frequencies to be filtered for greater efficiency.
Response time <20 ms



Reactive power compensation

Helps avoid penalties due to reactive power consumption.

Reactive power compensation of lagging (inductive) and leading (capacitive) currents in both consumption and generation. 0.7 inductive ... 0.7 capacitive.



Stage balancing

It optimizes the efficiency of loads, protecting the power supply of devices and avoiding unexpected protection trips or insulation losses in the wiring.

How does an active filter work?

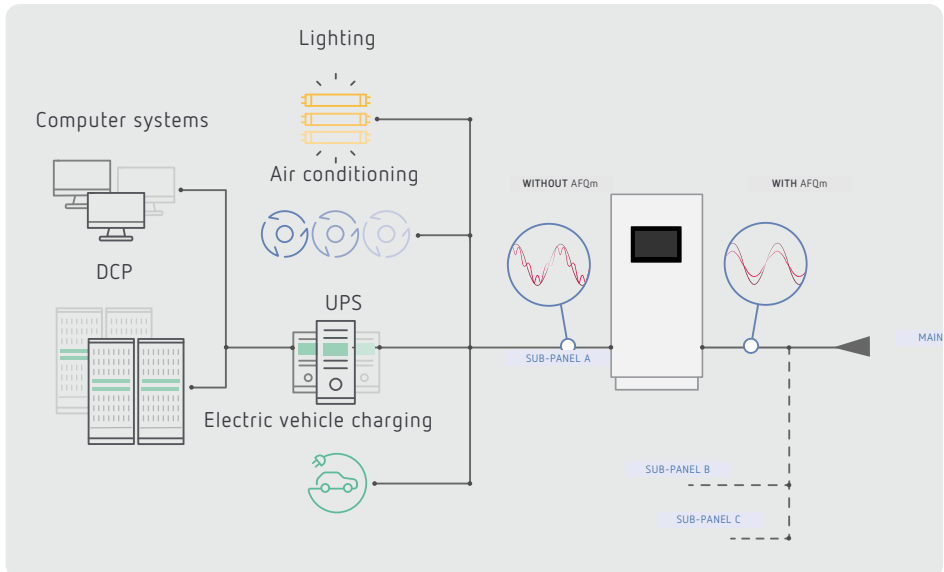

AFQs: It avoids problems caused by harmonics

Easier to install

AFQs has been designed to minimize space thanks to SiC technology. This feature means you can install it in the same panel with variable-speed drives or in small electrical rooms, even in shops or offices.



Essential to comply with IEEE 519:2022

The AFQs active filter has a touch screen that can be used to activate the filter system automatically as per the **IEEE 519** standard. When this function is activated, the device will adjust the power dedicated to filtering each harmonic to ensure that downstream loads do not exceed the limits specified in the **IEEE 519-2022** standard.

Conættar

Sæhfigurar

Stæðhættar



Fast start-up

Use the touch screen to connect the AFQs filter, fully configure it and start filtering in just three steps and a few minutes. Solve installation problems in current transformers, select if they are on the load side or network side, choose which harmonic to filter (up to 50) and monitor the status of any electrical parameter before and after start-up.

Maximum protection and service continuity



Safety first

The device has a self-diagnostic system during start-up that keeps it offline if any problems arise during installation. It will also display active or registered alarms on the screen, so you can easily review any incident.

Designed as per the **IEC-60730** standard, it does a self-diagnostic of both the software and the hardware executing it.

Smart thermal management

Adjusts the internal fan speed according to filtering needs. Adjusts the filtering rating when temperature is above the operating limit to ensure the device's life span.

Safe mode

Keeps the filter from connecting automatically by setting a minimum start-up current, preventing injection when not required.

Anti-resonance system

The device avoids operating in resonance frequencies (specific harmonics) and continues operating in the rest of the spectrum without affecting its operation. Re-enables the deactivated harmonics when the resonance status disappears.



Expandable at any time

AFQs devices can work with each other as a Master-Satellite, with up to 100 filters connected in parallel managed from a single master. This option saves costs by avoiding having to install current transformers in the devices to function as satellites.

Visual, more functions

Check for changes in your installation's electrical parameters

Operational status of the filter
Powers and harmonic distortion before and after the filter.

Instantaneous parameters

- > Voltages, currents, active power, inductive reactive power, capacitive reactive power, apparent power, THDU%, THD/% and cos phi
- > Individual voltage and current harmonics (before and after the filter)
- > Phasor diagram
- > Voltage and current waveform (before and after the filter).



Monitors instantaneous values



Filters harmonics as per IEEE 519



View any operating alarm

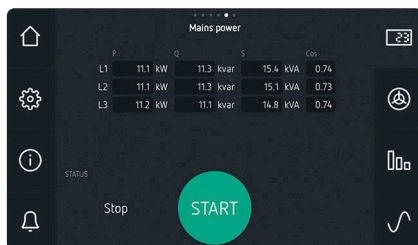

Status of reactive energy and cos fi

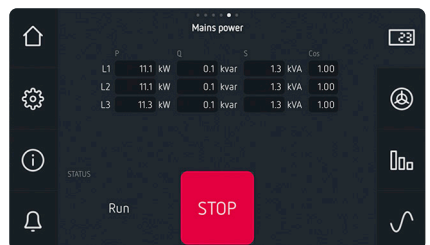

Reactive energy and cos fi compensation

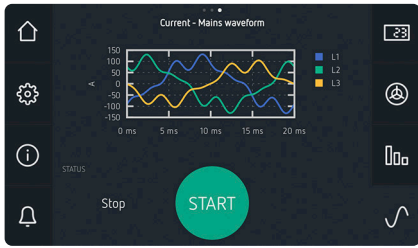

In-line/load waveform

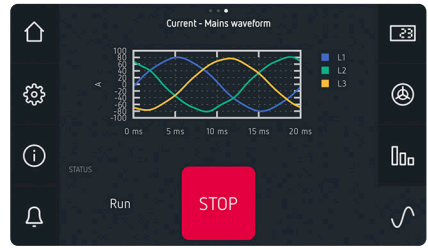

Waveform after the AFQs



In-line/load harmonics

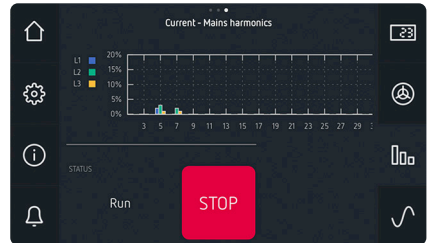

Harmonics after the AFQs



In-line/load phasor diagram

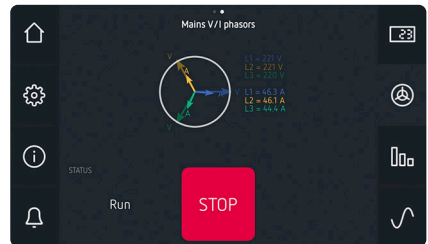

Phasor diagram after the AFQs

Always connected

The **AFQs** active filter has an Ethernet port with an integrated web server to let you access its configuration, monitor it and download files from any web browser locally or remotely.

The device has 2 GB memory, recording every electrical parameter every minute for up to 7 years. In addition, for maintenance work, you will have an alarm log with the parameters from the last 5 seconds before the alarm activation so you can easily interpret the event.

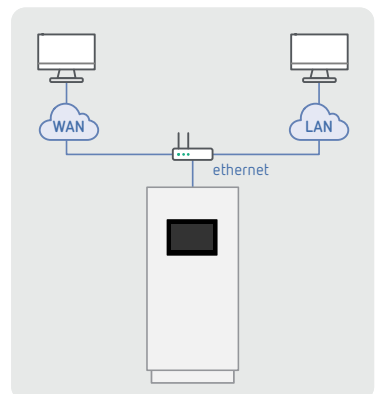

AFQs

Where to install the filter

The **AFQs** active filter is especially designed to be installed directly in the control panel housing the load that is generating the harmonics. It can be installed directly in the same cabinet or in any electrical room. Its reduced weight and size make it easier to install on the wall without additional fastening elements.



Variable speed drives



Lifts

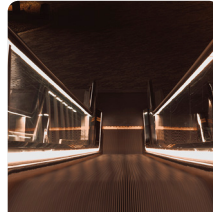

Escalators

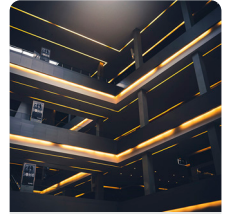

LED lighting



Cooling systems



EV charging

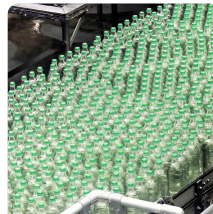

Conveyor belts

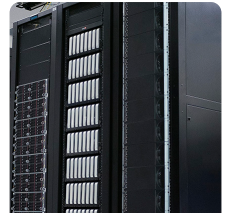

UPS

Technical specifications

Electrical specifications	Phase-Phase voltage	208...480 V ($\pm 10\%$)
	Frequency	50 Hz / 60 Hz
	Type of connection	3 phases (3 wires)
Current measurement circuit	Transformation ratio	5/5 A ... 20000/5 A
Filter specifications	Range of current harmonics	From the 2nd to 50th harmonic
	Selection of harmonics	From the 3rd to 49th harmonic (odd only)
	Balanced current function	Implemented
	Reactive energy compensation function	Implemented
	Controller technology	DSP (digital signal processor)
	Transient response time	< 20 ms
	Overcurrent protection	Protection to limit current to the filter's rated current
On-screen functions	Control options	Filter ON/OFF, alarm reset, and filter status description
	Programmable functions	Select the harmonics to be filtered, enable the balancing function and/or the reactive power compensation function, current transformer ratios, minimum operating current, control algorithm and number of AFQs units in parallel
	Electrical parameter readings	Values of voltages, currents, active, reactive and apparent power, power factor. Current harmonics and harmonic spectrum tables
Communications	Ethernet TCP/IP	Modbus TCP / http (Web Server)
Environmental conditions	Operating temperature	-20... 50 °C
	Storage temperature	-20... 50 °C
	Humidity	0... 95%
	Protection Rating	IP 20
Mechanical Characteristics	Dimensions	205 x 490 x 201 mm
	Weight	13 kg
	Attachment	Wall
	Enclosure	1.5 mm galvanized steel
Standards	IEC 62477-1, IEC 61000-6-2, IEC 61000-6-4, UNE-EN 60068-2-1, UNE-EN 60068-2-2, UNE-EN 60068-2-78, UNE-EN 60068-2-64, UNE-EN 60068-2-6	

References

Type	Code	System	Phase current	Peak current	Communications
AFQs-3WF-030M	R7MS0F.	3 wires, 208...480 V	30 A	60 A	Ethernet, Modbus/TCP

Circutor

Vial Sant Jordi, s/n
08232 Viladecavalls
Barcelona (Spain)
t. +34. 93 745 29 00
info@circutor.com

CIRCUTOR, SAU reserves the right to modify any
information contained in this catalogue.